

Repair Tips For Your Sportscar

Hello from Gillspeed. This is the fourth issue of the Gillspeed Bulletin for 1991. By now you should have received the updated issue of our Sprite and Midget catalogue. If not, please give us a call.

As you read through this bulletin you may think of a topic you would like explained in a future bulletin, if you do, please let us know.

Four more 'Tricks of the Trade'.....

1-Fitting piston rings.

Fitting piston rings can be a worry if you have never done it before. The flexible steel segmented oil rings are no problem as long as you remember to stagger the gaps and check that the ends of the expander have not overlapped. Cast iron compression and oil rings are easily broken.

If you practice the following method with some old rings, you will soon become an expert. Starting with the bottom cast iron ring, hold both ends of the ring in the desired groove with both thumbs, and then move your thumbs equally in opposite directions around the piston, pushing the ring over the top of the piston and into its groove as you go.



2-Speedo cable fitting.

When your inner speedo cable breaks, it is usually due to old age. It may also be because of sharp turns or kinks in the outer cable, or even a seized speedo unit. When you fit a new cable, always fit the speedo end first, and then give the inner cable a twist by hand at the gearbox end to make sure the inner cable turns freely.

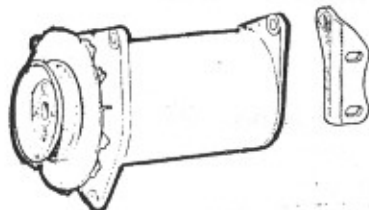

3-How to avoid broken generator lugs.

Have you ever wondered why the mounting lugs break off Lucas generators? The usual reason is the incorrect location of the rear mounting bracket bolted to the side of the engine. On BMC 'A' & 'B' series motors, this rear mounting bracket is slotted to allow for adjustment. The trick is to leave its two mounting bolts loose until everything else is tight, thus taking the stress off the generator lugs.

4-The solution to low oil pressure in 'A' Series engines.

Here is a tip for people rebuilding BMC 'A' Series motors. Always fit a new set of cam bearings because the centre cam bearing wears and leaks excessively, robbing the crankshaft of oil pressure. Some early Sprite and Midget blocks with '9C' engine number prefixes had one white-metal bearing only, fitted at the front. The middle and rear camshaft journals ran directly in the cast iron block. These early type blocks will require machining to accept whitemetal bearings. New cam bearings are the secret of good oil pressure. It is also a good idea to 'Loctite' the rear cam bearing into the block. They often come loose!

How good is your fuel economy? A Boeing 747 Jumbo uses around eleven tons of fuel an hour. The old Queen Mary used around one gallon every thirteen feet!

Stay warm & dry this winter.

If you drive a Sprite, Midget, MGA, MGB, TD, Spitfire, TR, or 'E' Type Jaguar, you will know the difficulty of keeping the inside of your car dry in winter. You may not know that Gillspeed stocks new soft tops for all the cars listed above. If you would like a smart looking new concours quality imported top for your car, with watertight welded top seams and windows, call Gillspeed today. We can also supply you with used hood bows for most models, plus all the parts you need to convert your early MGB to the later 'fold back' style roof. These tops are very easy for you to fit yourself at home.

We are always looking for old Sprite and Midget front shock absorbers and wishbones, plus any other bits and pieces lying around in your shed. Send us a list today and we will work out a price and delivery to Gillspeed.

P.T.O.

New Parts For Your Sportscar

The latest reproduction parts:

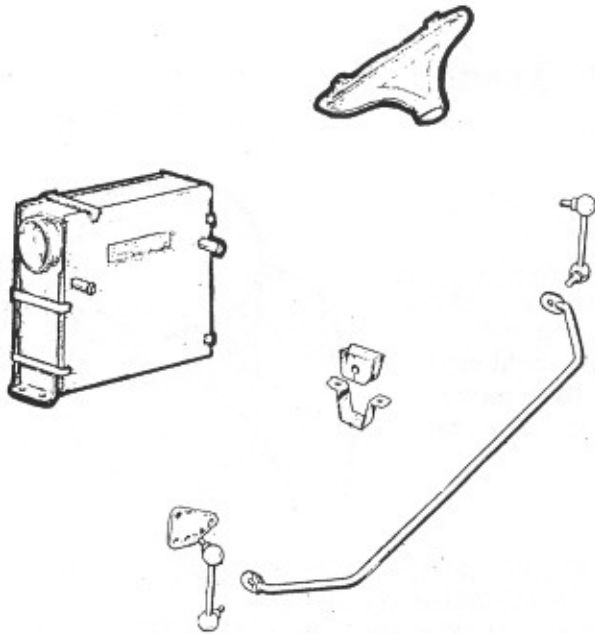

Sprite & Midget Demister Vents.

You can now obtain Gillspeed reproduction demister vents for your Sprite or Midget. They will keep your windscreen fog free this winter. If you would like a heater to go with the demister vents we have a small number of used factory heater boxes & fans available.

Heavy Duty Stabiliser Bars.

You are now able to obtain a heavy duty Gillspeed front stabiliser bar to replace your standard diameter factory bar. It comes with two matching 'D' rubbers.

Complete bar and fitting kits are also available for cars not presently fitted with a front stabiliser bar.

Negative Camber Trunnions.

Negative camber trunnions are also in stock. These replace the standard trunnions and are essential for competition cars.

Tiger Rides : If you are ever passing through Geelong and fancy a ride down the coast to Bells Beach in a Tiger Moth, the MG driver you need to talk to is Roy Thorpe at Geelong Airport. Phone (052) 64 1273 and book a few days ahead. Flying jacket and goggles are supplied.

The Shocking Facts About Reds :

As well as our regular 'Black' changeover shock absorbers, Gillspeed is now also producing 'Red' changeover units. Red units are uprated and are built from selected premium quality core units. As a result, supply is limited for some models.

We are often asked what is actually done to Gillspeed changeover shock absorbers. The following explanation should give you a clear picture of the reconditioning process. All old units are first hot tank cleaned, dismantled and thoroughly inspected. The bodies are then line bored and fitted with Australian Flocast bronze bushes. Polished and sized shafts are fitted to the newly reamed bushes. New twin lip seals are fitted, the valves are reset to 'standard' or 'uprated' settings and the assembled units are pressure tested for leaks prior to painting. If your car is fitted with lever shockers and rides like a ship on the high seas, give Bob or Derek call on (03) 568 0688.

In the next Gillspeed Bulletin : we will explain why fitting tapered roller front wheel bearings to your Sprite or Midget may be very dangerous to both car and driver.....and we will also tell you the easy way to refit your propellor shaft into the back of your gearbox.

Ordering and payment is easy.

Phone your order through today on (03) 568 0688, or FAX it to Gillspeed on (03) 568 0043, or mail it to..... You can use Bankcard, Mastercard, VISA, by phone or FAX, mail a cheque or use C.O.D Mail.

REPLY PAID 13

GILLSPEED SPORTSCARS

48 REGENT ST.

OAKLEIGH VIC. 3166.

(No postage stamp required)

ORDER TODAY AND THEY ARE ON THE WAY.